

Clarke®



WARNING: Read these instructions before using the machine

PETROL DRIVEN POWER WASHER

MODEL NO: TIGER 3000A

PART NO: 7320211

OPERATION & MAINTENANCE INSTRUCTIONS

CE

ORIGINAL INSTRUCTIONS

LS0820 - ISS 2

INTRODUCTION

Thank you for purchasing this CLARKE Petrol driven power washer.

Before attempting to use this product, please read this manual thoroughly and follow the instructions carefully. In doing so you will ensure the safety of yourself and that of others around you, and you can look forward to your purchase giving you long and satisfactory service.

GUARANTEE

This product is guaranteed against faulty manufacture for a period of 12 months from the date of purchase. Please keep your receipt which will be required as proof of purchase. This guarantee is invalid if the product is found to have been abused or tampered with in any way, or not used for the purpose for which it was intended.

Faulty goods should be returned to their place of purchase, no product can be returned to us without prior permission.

This guarantee does not effect your statutory rights.

ACCESSORIES

The range of accessories listed below are available from your CLARKE dealer.

| ITEM | PART NUMBER |
|--|-------------|
| 5 Litres Detergent (Traffic Film Remover) | 3050821 |
| 25 Litres Detergent (Traffic Film Remover) | 3050820 |
| 5 Litres Wash 'n' Wax | 3050815 |

GENERAL SAFETY RULES



WARNING: Water at high pressure can be dangerous and can cause damage if the operator is careless. Never allow anyone to operate this pressure washer unless they are familiar with the safety precautions.

1. **DO NOT** point the spray at other people, animals, electrical equipment or the machine itself.
2. **DO NOT** hold your finger over the high pressure nozzle.
3. **DO NOT** let children or untrained personnel use this machine.
4. **DO NOT** operate the machine with any of the covers removed.
5. **DO NOT** try to repair this machine. Always refer to your CLARKE service department for all repairs.
6. **DO NOT** supply any liquid other than water to the water inlet.
7. **DO NOT** use the detergent pickup facility to introduce flammable liquids/ solvents, e.g. paint thinners, petrol, oil as there is a risk of explosion.
8. **ALWAYS** release the remaining pressure in the system turn off the water supply and operate the trigger before you remove hoses or accessories.
9. **ALWAYS** keep the machine dry and away from the water spray.
10. **ALWAYS** use protective clothing and safety glasses. Loose particles and other items can be propelled at high speed by the water spray.
11. **ALWAYS** hold the gun securely and expect it to 'kick' when you pull the trigger.
12. **ALWAYS** respect the requirements of the local water company. Pressure washers may only be connected to the mains water supply if a system separator (also known as a backflow preventer) is installed in the supply hose.
13. **ALWAYS** disconnect from the water supply, and make sure that you drain the system when not in use. Keep in a cool dry location.
14. **ONLY** use detergents that are suitable for pressure washers, we recommend that you use CLARKE Traffic Film Remover or CLARKE Wash and WAX (available from your dealer).
15. **WARNING** High pressure hoses, fittings and couplings are important for the safety of the machine. Use only hoses, fittings and couplings recommended by the manufacturer.
16. **WARNING** Water that passes through a system separator (also known as a backflow preventer) is not safe to drink.
17. **DO NOT** use the pressure washer if there is damage to the inlet/outlet hose or the machine.

SAFETY SYMBOLS

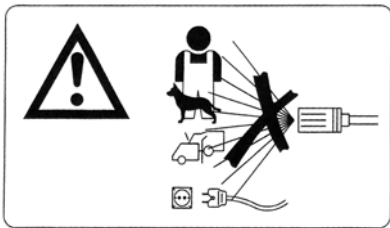

WARNING: Do not direct discharge stream at persons or animals. Keep clear of nozzle.

WARNING: Never direct spray toward any electrical device or electrical outlet.



General Warning, indicates that failing to follow these instruction could result in injury or damage to the machine.



To reduce the risk of injury, read the manual before use.

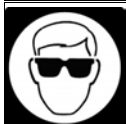

ALWAYS wear safety glasses when using this machine.



WARNING: No open flame, open ignition source and smoking is prohibited



WARNING: No smoking



DANGER: Risk to breathing. Engine exhaust fumes can kill. For outdoor use only. Work in a well ventilated area.



WARNING: Risk of injection or severe injury. Do not direct discharge stream at persons or animals. Keep clear of nozzle. This machine is to be used only by qualified operators.

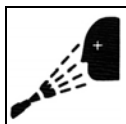

WARNING: Risk of spray injury. Spray can propel objects. Always wear ANSI approved Z87.1 Safety Glasses.



WARNING: Risk of chemical burn. Never spray acids, corrosive or toxic chemicals. Use only cleaners formulated for pressure washers.



WARNING: Risk of electrocution. Never direct spray toward any electrical device or electrical outlet.



WARNING: Risk of unsafe operation. Keep children away from this equipment. Gun kicks back. Hold with both hands.



WARNING: Risk of hot surfaces.

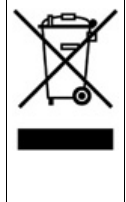

Recycle unwanted materials instead of disposing of them as waste. All tools, accessories and packaging should be sorted, taken to a recycling centre and disposed of in a manner which is compatible with the environment.

OVERVIEW

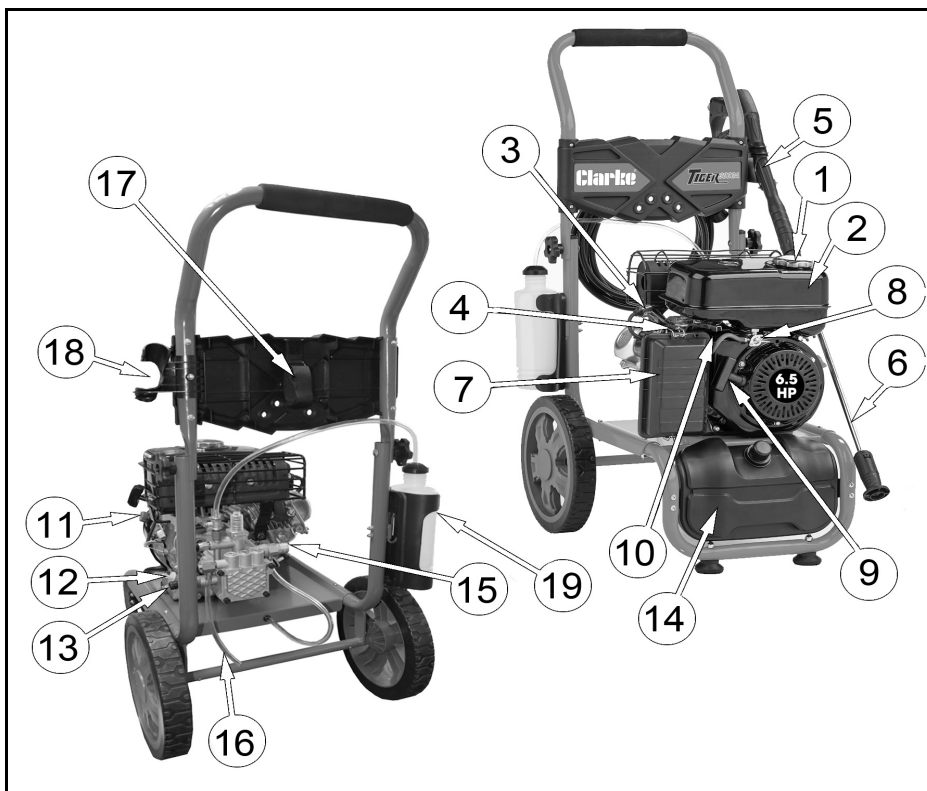

| NO | DESCRIPTION | NO | DESCRIPTION |
|----|-------------------|----|----------------------|
| 1 | Fuel Tank Cap | 11 | Engine On/Off Switch |
| 2 | Fuel Tank | 12 | Oil Filler Cap |
| 3 | Spark Plug | 13 | Water Outlet |
| 4 | Choke | 14 | Detergent Tank |
| 5 | Gun Assembly | 15 | Water Inlet |
| 6 | Lance | 16 | Bypass Drain Hose |
| 7 | Air Filter Cover | 17 | Hose Holder |
| 8 | Fuel Valve | 18 | Lance Holder |
| 9 | Recoil Pull Start | 19 | Priming Bottle |
| 10 | Throttle | | |

ASSEMBLY

Unpack your pressure washer and check to ensure the following items are present.

Contact your CLARKE dealer immediately if any parts are missing or damaged.

| | |
|-------------------------------------|---|
| 1 x Power Washer | 2 x Wheel & Axle Assembly |
| 1 x Hose Bracket c/w Fixings | 1 x Nozzle Cleaning Pin |
| 1 x Gun / Lance Bracket c/w Fixings | 1 x Tap Adaptor |
| 1 x Hose | 1 x Detergent Hose c/w Filter |
| 1 x Lance Assembly | 1 x Upper Handle c/w Fixings |
| 1 x Gun Assembly | 1 x Engine Manual |
| 1 x Spark Plug Box Spanner | 1 x 3m Inlet water hose |
| 1 x Tommy Bar | 1 x Water Filter (may be supplied already fitted) |

CONNECTING THE WHEELS

- Slide the axles into the locating tube as shown.
 - Make sure the ball catch locks into the small hole on the bottom of the locating tube.
- Add the 2 axle covers as shown.

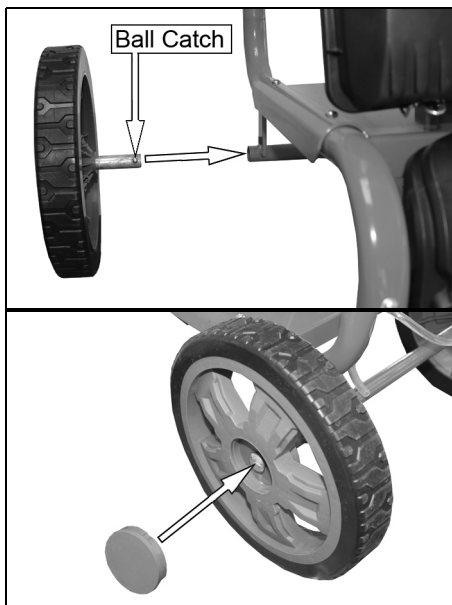

CONNECTING THE HANDLE

1. Slide the upper handle into position as shown.
2. Secure using a bolt and handwheel.
 - The handwheel should be on the outside.

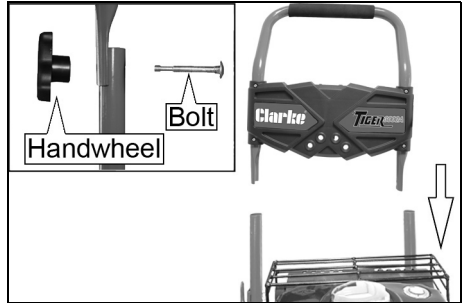

FITTING THE WATER BOTTLE

NOTE: The water bottle is only used when drawing water from an unpressurised source such as a water butt. See page 16.

1. Fit the bracket to the frame as shown using the bolts, nuts and washers supplied.
2. Slide the bottle holder over the bracket and place the bottle in the holder.

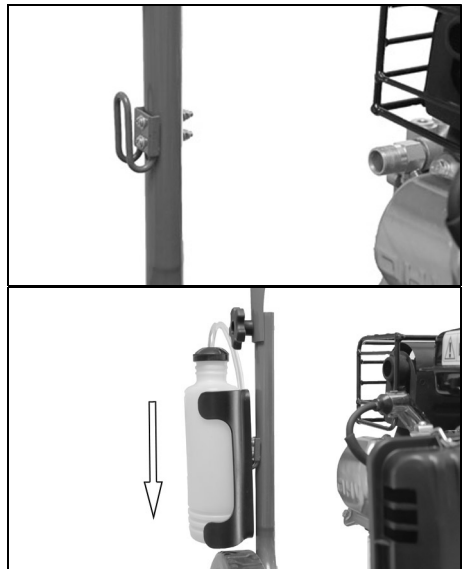

FITTING THE LANCE/HOSE HOLDER

Fit the holders into the positions shown and secure using the washers and nuts provided.

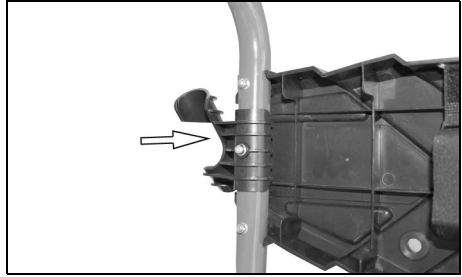

CONNECTING THE HIGH PRESSURE HOSE

CONNECT THE HOSE TO THE GUN

1. Screw the high pressure hose onto the gun assembly.
- Tighten the connector, hand tight only. Do not use a spanner.

NOTE: Make sure the connection is secure.

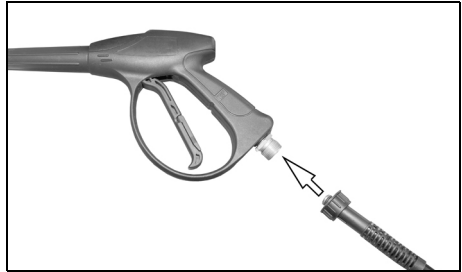

CONNECT THE HOSE TO THE PRESSURE WASHER

1. Screw the hose on to the pressure washer.
- Tighten the connector, hand tight only. Do not use a spanner.

NOTE: Make sure the connection is secure.

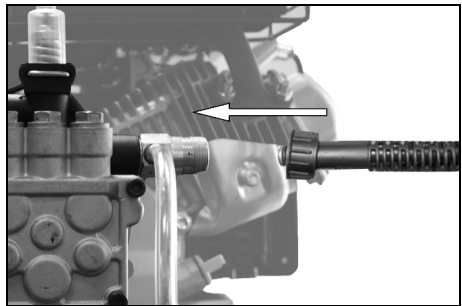

ASSEMBLING THE LANCE

Connect the spray lance to the gun assembly and tighten securely by turning the locking ring.

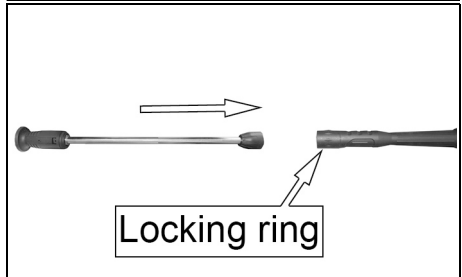

CONNECTING THE WATER SUPPLY

Always follow the regulations of your local water supplier. The pressure washer must never be connected to the drinking water supply without using a system separator (also known as a backflow preventer) available from most hardware stores.

NOTE: Water that has flowed through a system separator is considered non-drinkable.

1. Connect a water supply hose (not supplied) to the water inlet.
- Make sure that the water filter is installed behind the hose connector on the water inlet

NOTE: Use a good quality fibre-reinforced water hose with a standard coupling.

NOTE: This machine has the ability to draw its own water, meaning you can use water not under pressure such as rainwater collected in a water butt. See page 16.

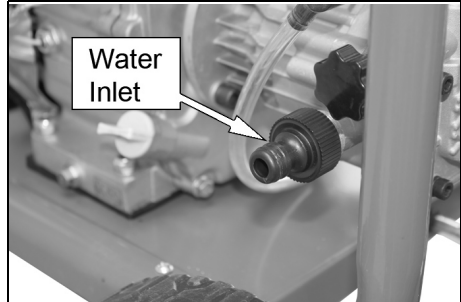

BEFORE USE



WARNING: STAND THE PRESSURE WASHER ON LEVEL GROUND WITH THE ENGINE SWITCHED OFF.

WARNING: TAKE CARE NOT TO TOUCH ANY HOT PARTS OF THE PRESSURE WASHER WHEN CHECKING THE OIL LEVEL.

IMPORTANT: *The engine is supplied without any oil in it and must be filled to the correct level before use, see below.*

ENGINE OIL

1. Turn the oil filler cap anticlockwise and remove it from the engine, wipe the integral dipstick with a clean cloth.

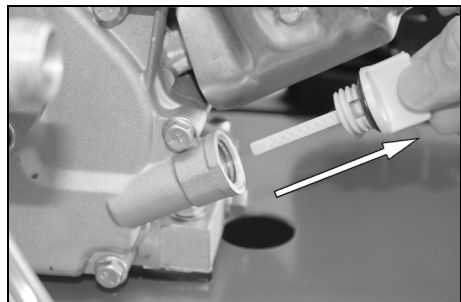

2. Insert the oil filler cap back into place and then remove it again.
3. If the oil reads low on the dipstick, add oil to the oil reservoir (Max 0.6L).
 - We recommend the use of SAE10W-30 oil.
 - Do not overfill the oil reservoir.
4. Replace the oil filler cap.

NOTE: Running the engine with insufficient oil will cause engine damage.

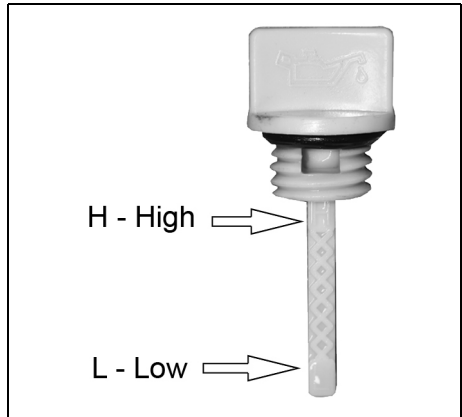

FUEL



WARNING: REFUEL IN A WELL-VENTILATED AREA, AWAY FROM ANY SOURCES OF IGNITION.

WARNING: IF THE ENGINE HAS BEEN RUNNING, ALLOW IT TO COOL BEFORE REFUELING.

WARNING: DO NOT LEAVE FUEL WITHIN THE REACH OF CHILDREN.

WARNING: REFUEL CAREFULLY TO AVOID SPILLING FUEL.

1. Remove the fuel tank cap.
 - Just inside the fuel tank is a fuel strainer, which should be checked periodically and any contaminants which have accumulated must be removed.
2. Pour unleaded petrol through the fuel strainer and into the fuel tank.
 - Do not fill above the fuel strainer shoulder.
 - Use unleaded petrol with a pump octane rating of 86 or higher.
3. Replace the fuel filler cap securely.



MAXIMUM FUEL LEVEL

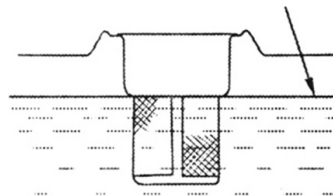

STARTING YOUR PRESSURE WASHER

1. Turn the water supply on, making sure that the tap is fully open.



WARNING: FAILURE TO TURN ON THE WATER COULD CAUSE DAMAGE TO THE PRESSURE WASHER.

2. Set the choke lever to the CLOSE position.

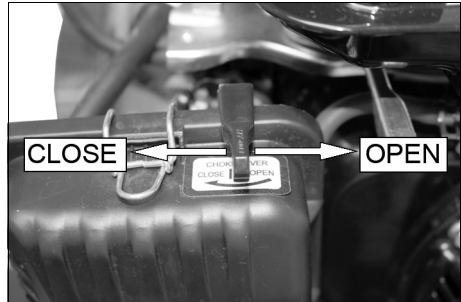

3. Set the fuel supply valve to the ON position.

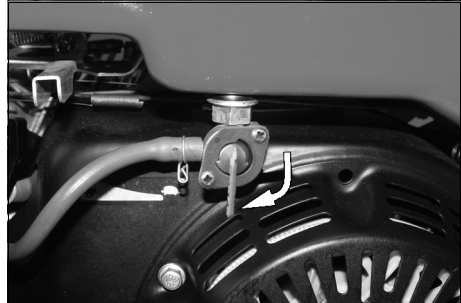

4. Slide the throttle lever to the left approximately 3/4 of the way.

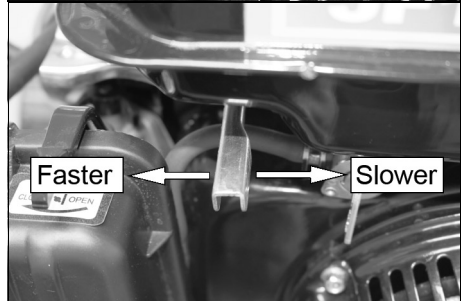

5. Set the engine switch to the on (I) position.

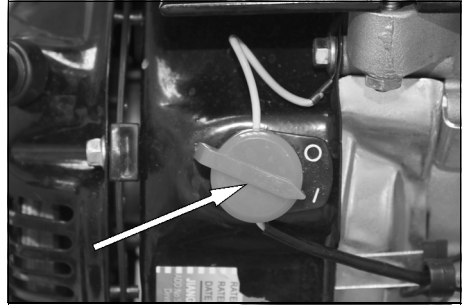

6. Pull the recoil starting handle lightly until you start to feel resistance and then pull up sharply to start the engine.

- You may have to do this more than once.

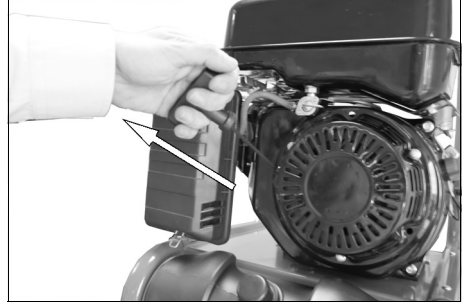

WARNING: ONCE THE PRESSURE WASHER ENGINE HAS STARTED, RELEASE THE STARTING HANDLE SLOWLY TO AVOID INJURY/DAMAGE AS IT RECOILS.

7. Once the engine has warmed up, slide the choke lever to the OPEN position.

- The pressure washer is now ready for use.

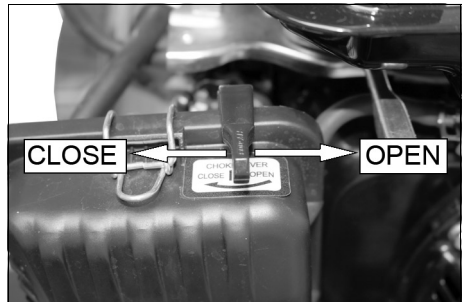

8. Release the trigger lock.

9. Ensuring that you have a firm footing and that you are also holding the gun assembly and spray lance firmly, pull the trigger on the gun to start water flow.

- The lance and gun will kick back when the trigger is first pulled.

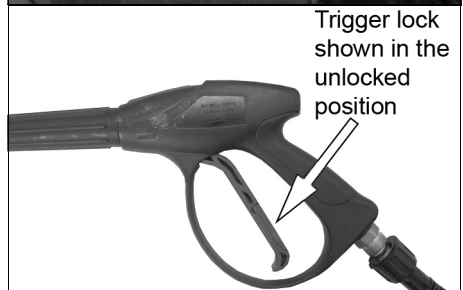

INTERRUPTING OPERATION

1. Release the trigger.

NOTE: The pressure washer will automatically go into bypass mode.



WARNING: DO NOT ALLOW THE UNIT TO OPERATE IN BYPASS MODE FOR MORE THEN TWO MINUTES AT ANY TIME. TURN THE UNIT OFF IF IT IS NOT GOING TO BE USED FOR LONGER THAN THIS. SEE PAGE 14.

NOTE: If you notice water coming from the drain tube attached to the pump, please note that this is a safety feature and should be expected, it cools the pump by releasing some of the hot water within the pump and replacing it with fresh 'cool' water.

2. Rotate the trigger lock to the locked position.



ADJUSTING THE SPRAY NOZZLE

The nozzle is adjustable to allow you to adjust the water delivery from a narrow jet of water to a wide spray. To adjust the nozzle, proceed as follows:

1. Hold the shaft of the lance in one hand.
 2. Twist the nozzle with the other hand.
- The spray varies between narrow and wide as you turn the nozzle.



ADJUSTING THE PRESSURE

The machine output is preset at the factory. To lower the contact pressure:

1. Back away from the surface to be cleaned. The further away you are the less the pressure will be on the surface being cleaned.
2. Reduce the speed of the engine using the throttle. Slow the engine down and the water pressure will also go down.
3. Adjust the spray to a wider angle.
4. Hold the rear of the nozzle and slide the front of the nozzle forwards to low pressure and backwards for high pressure. See page 14.

APPLYING DETERGENTS AND CLEANING AGENTS

To improve the cleaning performance, you can introduce chemical cleaning agents (detergents) to the water jet using the detergent pickup hose.

1. Remove the detergent tank cap
2. Fill the tank with a suitable CLARKE detergent and replace the cap.

- Only use detergents recommended for use with pressure washers, such as CLARKE Traffic Film Remover which is a powerful low foaming agent for car cleaning, patio cleaning etc., or CLARKE Wash & Wax, both available from your CLARKE dealer.

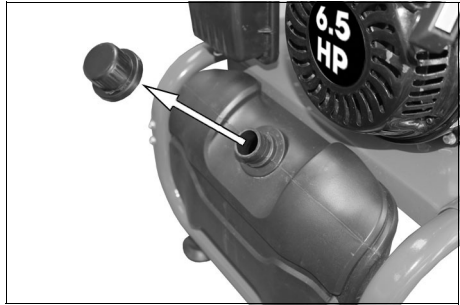

3. Hold the rear of the nozzle on the high pressure lance and slide the front of the nozzle forwards to low pressure.

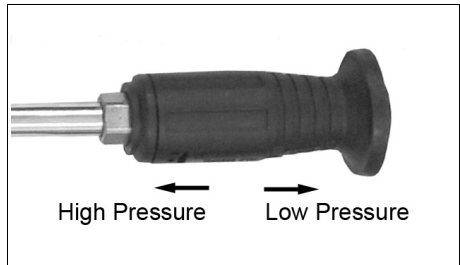

4. Spray the detergent onto the vehicle, patio etc.
- Allow the detergent a little time to work itself into the grime.



CAUTION: IF YOU GET CLEANING FLUID IN YOUR EYES, RINSE THEM IMMEDIATELY WITH PLENTY OF FRESH CLEAN WATER. AND SEEK MEDICAL ADVICE IF REQUIRED.

5. To rinse, slide the front of the nozzle on the lance back towards the handle and use the pressure washer as normal.

SHUTTING DOWN

1. After each use, if you have applied chemicals, slide the front of the nozzle on the lance back towards the handle and operate the pressure washer for a short time to flush the hoses.
2. Move the throttle control lever to the right.

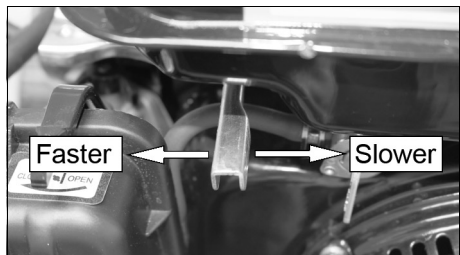

3. Turn off the engine switch, to the off (O) position.
4. Turn water supply off at the tap.
 - NEVER turn the water off with the engine running.
5. Release the pressure in the pump and hose by squeezing the trigger for a few seconds until no more water comes out of the nozzle.
6. Turn the fuel supply valve to the OFF position.

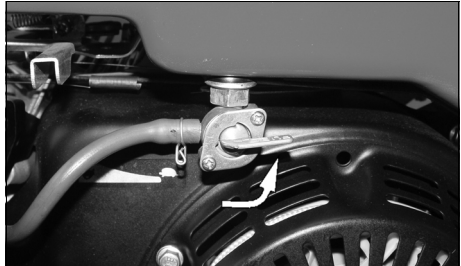
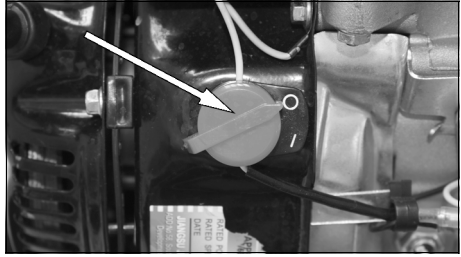

7. Rotate the trigger lock to the locked position.

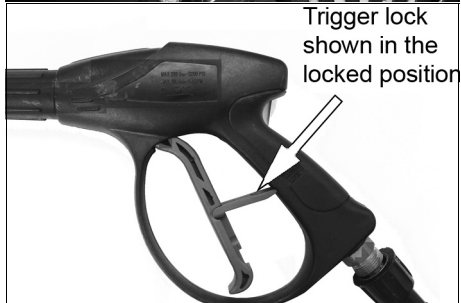

WATER BUTT CONNECTION

This machine has the ability to draw its own water, meaning you can use water not under pressure such as rainwater collected in a water butt.

To do this you must carry out the following procedure.

1. Remove the quick connector from the water inlet.

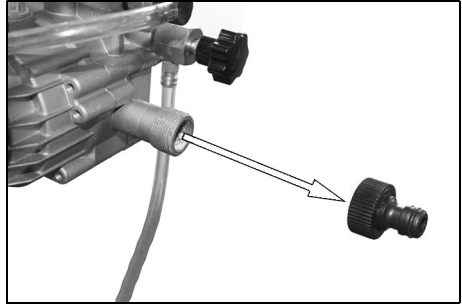

2. Attach the filter to the end of the braided pipe supplied.

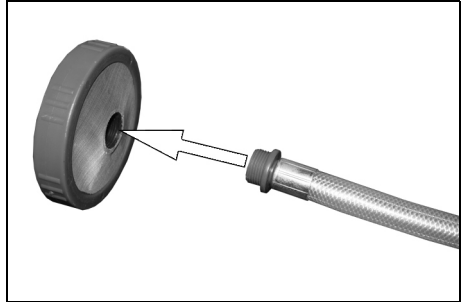

3. Remove the water inlet filter

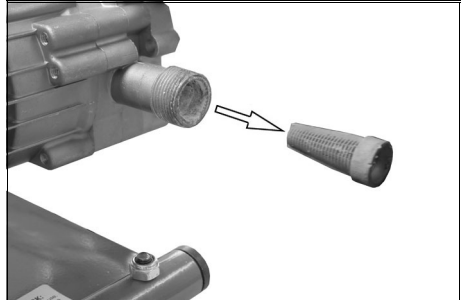

4. Connect other end of the braided pipe to the water inlet.

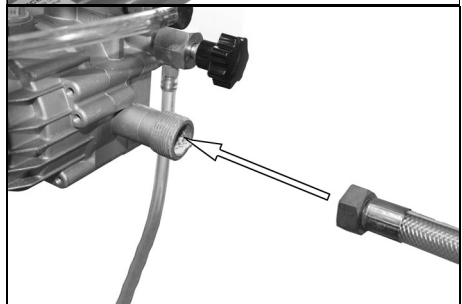

5. Fill the priming bottle with water.
6. Connect the hose from the bottle to the self-suction valve shown.
7. Place the filter into the water source and start the pressure washer, See "Starting your pressure washer" on page 11.
8. Release the exhaust valve.

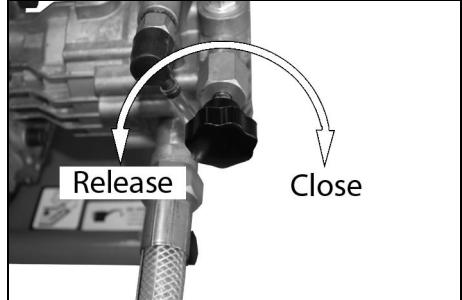
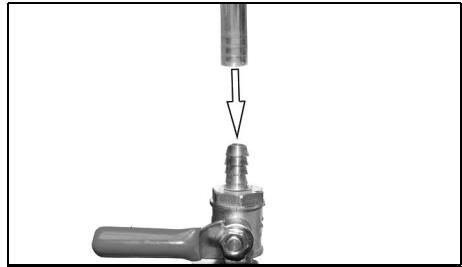

9. Turn the self-suction valve to the on position.

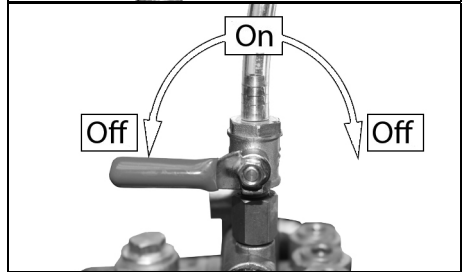

10. Release the trigger lock and pull the trigger.
11. When the water spray is at high pressure, close the exhaust valve and set the suction valve to the OFF position.



NOTE: If the water butt runs out of water, the pressure washer will need to be primed before use by repeating steps 4-10.

STORAGE

1. Disconnect the high pressure hose and drain all water from the hose.
2. Coil the hose and store the lance/hose in their respective holders located on either side of the pressure washer.

STORAGE PROCEDURE

Make sure that the pressure washer has been thoroughly cleaned before storing it in a clean dry place. For long term storage See page 20.

MAINTENANCE

CLEANING THE NOZZLE

1. Shut off the pressure washer and turn off the water supply.
2. Pull the trigger on the gun to release any water pressure.
3. Disconnect the lance from the gun assembly.
4. Remove any obstructions with the nozzle cleaning tool provided and back flush with clean water.
5. Direct water supply into the end of the lance for 30 seconds to back flush loosened particles.
6. Reconnect the lance to the gun assembly and turn on the water supply.

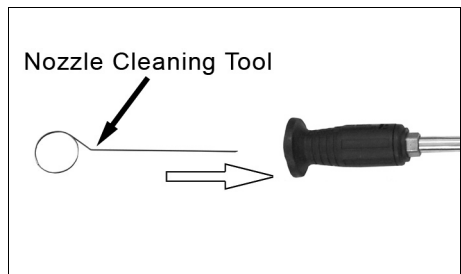

CLEANING THE WATER INLET FILTER

1. Remove the filter from the water inlet of the pump as shown.
 2. Clean the filter by flushing both sides with water.
 3. Replace the filter into the water inlet.
- Do not operate pressure washer without the filter properly installed.

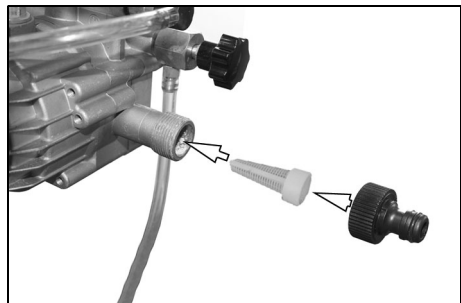

CLEANING THE FUEL STRAINER

Just inside the fuel tank is a fuel strainer. Inspect this periodically and remove any contaminants which may have accumulated.

1. Remove the fuel tank cap.



2. Remove the fuel strainer.
 3. Remove any contaminants.
 4. Replace the fuel strainer.
- Do not operate pressure washer without fuel strainer properly installed.



CLEANING THE AIR FILTER

1. Release the two clips on the air filter cover.
2. Remove the air filter cover.
3. Remove the air filter elements.
4. Wash the elements in a solution of warm water and mild detergent.



WARNING: DO NOT USE FLAMMABLE SOLVENTS OR PETROL TO CLEAN THE AIR FILTER

5. Rinse thoroughly and leave the elements to dry. Once it is completely dry, immerse the filter in clean engine oil and squeeze to remove excess oil.
- If the air filter is damaged contact CLARKE spare parts department for a replacement.
6. Replace the filter into its original position and refit the air filter cover.

CHANGING THE SPARK PLUGS



CAUTION: ALLOW THE ENGINE TO COOL BEFORE REMOVING THE SPARK PLUG.

1. Remove the spark plug cap from the spark plug.
2. Use the spark plug spanner supplied to remove the spark plug.
3. Remove any carbon that has accumulated around the sparkplug.
4. Check the spark plug gap (a), it should be between 0.7 and 0.8 mm, adjust if necessary.
5. Check the overall condition of the spark plug and replace if necessary.
6. Reinstall the spark plug and replace the spark plug cap.

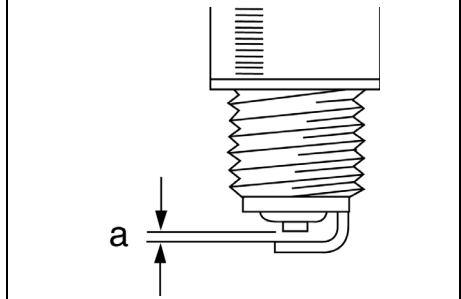
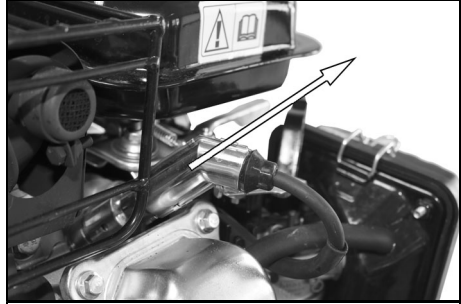

LONG TERM STORAGE

For long term storage,

1. The petrol tank should be drained.
 - Ensure that the engine is cold before draining the tank.
2. Remove the fuel tank cap and use a pump type syphon to drain the petrol into an appropriate, clean container.
 - Do not store petrol for long periods of time.
 - Dispose of excess petrol in an environmentally safe way. Your local recycling centre can advise you on the best method of disposal.
3. After the petrol tank has been drained, start the engine and allow it to use any petrol that may remain in the engine or fuel pipe.
4. Make sure that the power washer has been thoroughly cleaned before storing it in a clean dry place.

TROUBLESHOOTING

If the following does not solve your problem, please contact the CLARKE service department.

| PROBLEM | CAUSE | SOLUTION |
|--|--|--|
| Engine will not start (see engine manual for further engine troubleshooting) | No fuel. | Add fuel. |
| | Low oil. | Add oil. |
| | Pressure builds up after two pulls on the recoil starter or after initial use. | Squeeze the gun trigger to relieve the pressure. |
| | Spark plug lead not attached securely. | Attach the spark plug lead. |
| | Engine switch is in the OFF position. | Set the engine switch to the ON position. |
| | Choke lever is set to the ON position when the engine is already warm. | Set the choke lever to the OFF (right) position. |
| | Fuel valve closed. | Open the fuel valve. |
| Lack of pressure (initial use) | Leak in the high pressure hose fitting. | Tighten the fitting, use sealant tape if required. |
| | Nozzle is obstructed. | Clear the nozzle. |
| | Water filter screen is clogged. | Remove and clean the filter. |
| | Air in the hose. | Turn off the engine. Turn off the water supply. Disconnect the water source from the pump inlet and turn on the water source to expel the air from the hose. When all the air has been removed, turn off the water supply and reconnect the hose. Turn on the water supply and pull the trigger to expel any air in the gun/lance. |

| PROBLEM | CAUSE | SOLUTION |
|--|---|---|
| Lack of pressure (initial use) (continued) | Choke lever is in the OPEN position. | Set the choke lever to the OFF (right) position. |
| | Throttle control lever is not set high enough. | Move the throttle control lever to left. |
| | High pressure hose is too long. | Make sure the high pressure hose is under 100 feet. |
| Will not draw chemicals | Chemical filter is blocked. | Clean the filter. |
| | Chemicals being used are too thick. | Dilute the chemicals. The chemicals should have the consistency of water. |
| | High pressure hose is too long. | Use a longer supply hose instead of a very long high pressure hose. |
| | Chemical build up inside the chemical injector. | Have the parts cleaned or replaced by your dealer. |
| Lack of pressure (after a period of normal use) | Worn seal or packing. | Have them replaced by your dealer. |
| | Worn or obstructed valves. | Have them replaced by your dealer. |
| Water leaking at the pump | Loose connections. | Tighten. |
| | Worn or broken O-rings. | Have them replaced by your dealer. |
| | Pump head or tubes damaged from freezing. | Have it replaced by your dealer. See "Storage" on page 18. |
| Oil leaking at the pump | Oil seals worn. | Have them replaced by your dealer. |
| | Worn O-rings. | Check and replace. |
| Water leaking from the drain hose | Pump is overheating | This is a safety feature and should be expected. It cools the pump by releasing some of the hot water within the pump and replacing it with fresh 'cool' water. |
| Pump pulsates | Nozzle obstructed. | Clear the nozzle. |

SPECIFICATIONS

| | |
|----------------------------------|--------------------|
| MODEL NO | TIGER 3000A |
| ENGINE | |
| Engine type | Petrol (unleaded) |
| Capacity/displacement: | 196 cc |
| Oil Capacity | 0.6 L |
| Lubrication Grade | SAE10W-30 |
| Fuel Tank Capacity:(Litres) | 4 Litres |
| WATER CONNECTION | |
| Maximum Inlet Temperature | 60 °C |
| Maximum Inlet Pressure | 3-6 Bar |
| PERFORMANCE DATA | |
| Maximum Pump Pressure | 200 Bar |
| Working Pressure | 150 Bar |
| Maximum Water Flow | 8 l/min |
| NOISE & VIBRATION | |
| Sound Power Level LWA | 103 dB(A) |
| Guaranteed Sound Power Level LWA | 106 dB(A) |
| Uncertainty Factor K | 2.98 dB |
| Vibration | 3.398 m/s |
| Uncertainty Factor K | 1.5 |
| DIMENSIONS | |
| Length | 540 mm |
| Width | 630 mm |
| Height | 1020 mm |
| Weight | 31 kg |

EXPLODED DIAGRAM + PARTS LIST

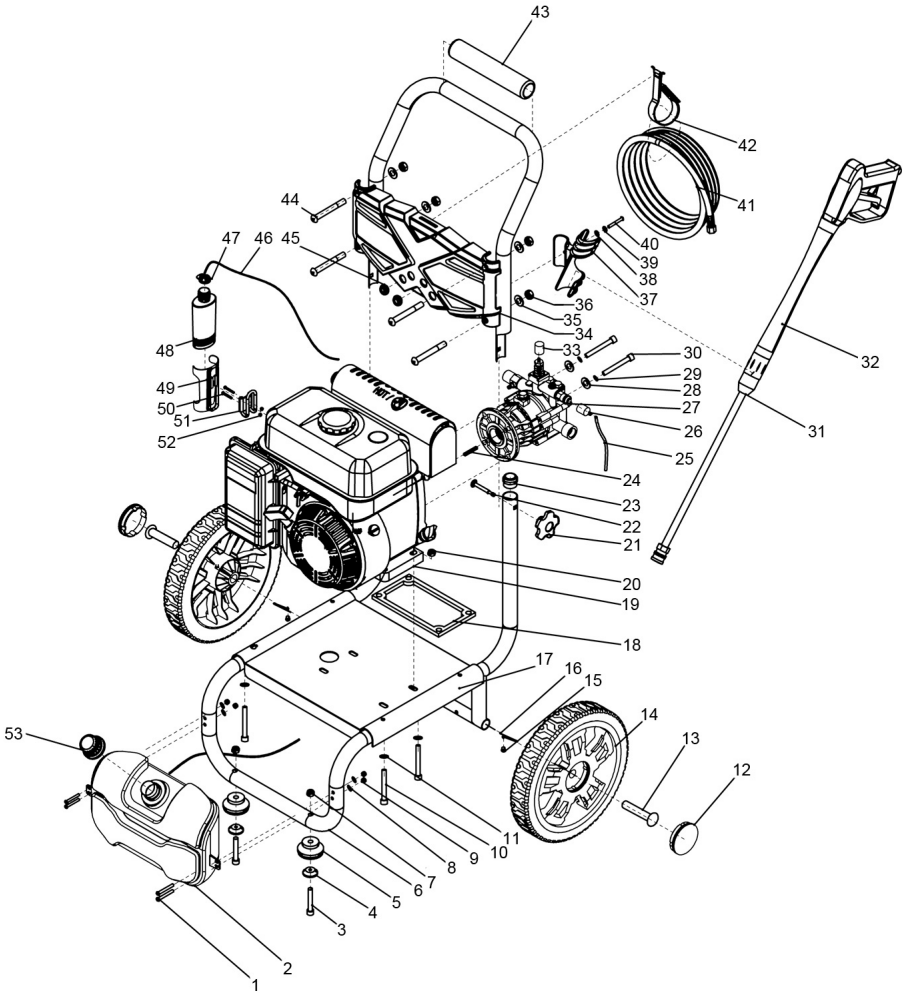

WARNING: TO ENSURE MACHINE SAFETY, USE ONLY ORIGINAL SPARE PARTS FROM CLARKE INTERNATIONAL.



| | | | | | |
|----|----------------------------|--------------|----|----------------------------|--------------|
| 1 | Cross Pan Head Screw M6x40 | RKTIG3000A01 | 32 | Gun | RKTIG3000A32 |
| 2 | Detergent Tank | RKTIG3000A02 | 33 | Overflow Valve Cover | RKTIG3000A33 |
| 3 | Inner Hexagon Bolt M8x42 | RKTIG3000A03 | 34 | Panel | RKTIG3000A34 |
| 4 | Rubber Foot Washer | RKTIG3000A04 | 35 | Locknut M8 | RKTIG3000A35 |
| 5 | Rubber Foot | RKTIG3000A05 | 36 | Flat Washer Ø5 | RKTIG3000A36 |
| 6 | Frame | RKTIG3000A06 | 37 | Gun Holder | RKTIG3000A37 |
| 7 | Locknut M8 | RKTIG3000A07 | 38 | Flat Washer Ø5 | RKTIG3000A38 |
| 8 | Flat Washer Ø6 | RKTIG3000A08 | 39 | Spring Washer Ø5 | RKTIG3000A39 |
| 9 | Locknut M6 | RKTIG3000A09 | 40 | Cross Pan Head Screw M5x16 | RKTIG3000A40 |
| 10 | Inner Hexagon Bolt M8x45 | RKTIG3000A10 | 41 | Hose | RKTIG3000A41 |
| 11 | Flat Washer Ø8 | RKTIG3000A11 | 42 | Hose Strap | RKTIG3000A42 |
| 12 | Hub Cover | RKTIG3000A12 | 43 | Handle Foam | RKTIG3000A43 |
| 13 | Wheel Shaft | RKTIG3000A13 | 44 | Cross Pan Head Screw M5x42 | RKTIG3000A44 |
| 14 | 11" Plastic Wheel | RKTIG3000A14 | 45 | Nozzle Grommet | RKTIG3000A45 |
| 15 | Clip | RKTIG3000A15 | 46 | Injection Hose | RKTIG3000A46 |
| 16 | Spring Wire | RKTIG3000A16 | 47 | Bottle Cap | RKTIG3000A47 |
| 17 | Baseboard | RKTIG3000A17 | 48 | Bottle | RKTIG3000A48 |
| 18 | Engine Cushion | RKTIG3000A18 | 49 | Bottle Frame | RKTIG3000A49 |
| 19 | Engine | RKTIG3000A19 | 50 | Cross Pan Head Screw M5x40 | RKTIG3000A50 |
| 20 | Locknut M8 | RKTIG3000A20 | 51 | Bottle Holder | RKTIG3000A51 |
| 21 | Hand Wheel | RKTIG3000A21 | 52 | Locknut M8 | RKTIG3000A52 |
| 22 | Square Neck Bolt | RKTIG3000A22 | 53 | Detergent Tank Cap | RKTIG3000A53 |
| 23 | Plug | RKTIG3000A23 | | | |
| 24 | Flat Key | RKTIG3000A24 | | | |
| 25 | Leading Sleeve | RKTIG3000A25 | | | |
| 26 | Drain Hose (320mm) | RKTIG3000A26 | | | |
| 27 | Pump | RKTIG3000A27 | | | |
| 28 | Flat Washer Ø8 | RKTIG3000A28 | | | |
| 29 | Spring Washer Ø8 | RKTIG3000A29 | | | |
| 30 | Inner Hexagon Bolt M8x25 | RKTIG3000A30 | | | |
| 31 | Lance | RKTIG3000A31 | | | |

DECLARATION OF CONFORMITY

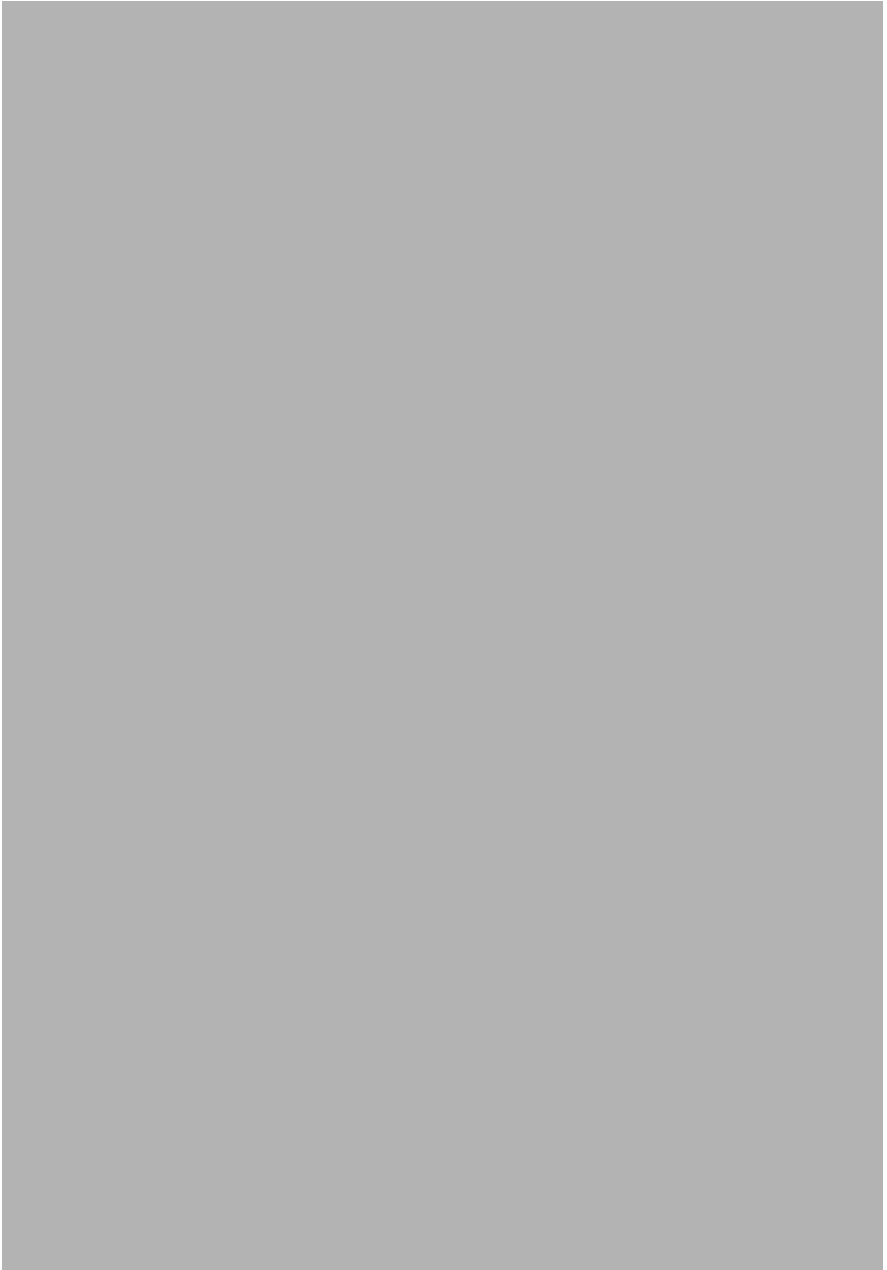

DECLARATION OF CONFORMITY

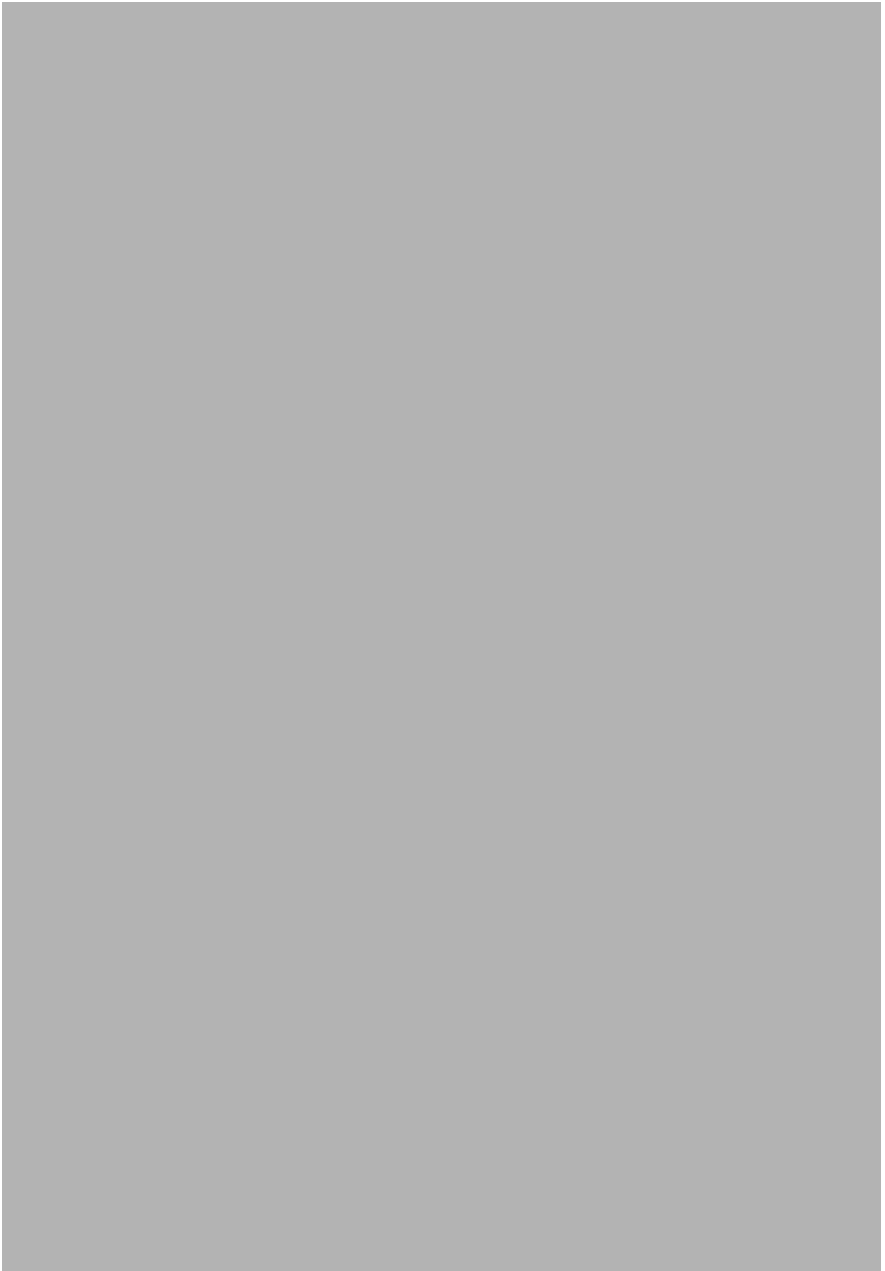

A SELECTION FROM THE VAST RANGE OF

Clarke®

QUALITY PRODUCTS



AIR COMPRESSORS
From DIY to industrial, Plus air tools, spray guns and accessories.

GENERATORS
Prime duty or emergency standby for business, home and leisure.

POWER WASHERS
Hot and cold, electric and engine driven - we have what you need

WELDERS
Mig, Arc, Tig and Spot.
From DIY to auto/industrial.

METALWORKING
Drills, grinders and saws for DIY and professional use.

WOODWORKING
Saws, sanders, lathes, mortisers and dust extraction.

HYDRAULICS
Cranes, body repair kits, transmission jacks for all types of workshop use.

WATER PUMPS
Submersible, electric and engine driven for DIY, agriculture and industry.

POWER TOOLS
Angle grinders, cordless drill sets, saws and sanders.

STARTERS/CHARGERS
All sizes for car and commercial use.



PARTS & SERVICE: 0208 988 7400

Parts Enquiries
Parts@clarkeinternational.com

Servicing & Technical Enquiries
Service@clarkeinternational.com

SALES: UK 01992 565333 or Export 00 44 (0)1992 565335

Clarke INTERNATIONAL Hemnall Street, Epping, Essex CM16 4LG
www.clarkeinternational.com